

PANEL COMPONENTS

SELECTOR SWITCH HEADS KEY OPERATED SHKO



Key operated selector switch head only with metal bezel. Standard 22.5mm hole fixing. Bayonet fixing with 2 angled screws.

General Characteristics

Standard	EN 60947-5-1
Operation	As below
Key	Ronis 455
Rated Voltage	380V
Rated Current	10A
Maximum number of contact blocks	6
Tightening Torque	0.5 Nm
Diameter of bezel	29mm
Depth of bezel with actuator	21mm
Back of panel depth ⁽¹⁾	43mm
Maximum thickness for fixing	7mm
Operating temperature	-5 to +40°C
Ingress protection	IP65
Weight	0.088Kg
<small>(1) with one contact fitted</small>	

Available configuration

SHK02M1	2 position maintained key removal one position
SHK02M2	2 position maintained key removal both positions
SHK02S1	2 position spring return key removal one position
SHK02S2	2 position spring return key removal both positions
SHK03ML	3 position maintained key removal left position
SHK03MR	3 position maintained key removal right position
SHK03MA	3 position maintained key removal all positions
SHK03MLR	3 position maintained key removal left & right positions
SHK03MC	3 position maintained key removal centre position

Available Accessories

CBC1NO	Contact block 1NO with collar
CBC1NC	Contact block 1NC with collar
CB1NO	Contact block only 1NO
CB1NC	Contact block only 1NC

Technical Drawing

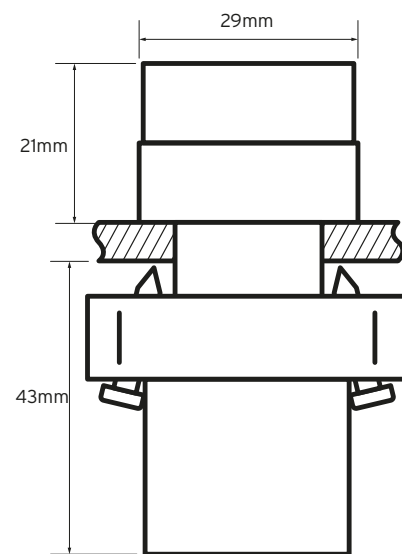

Additional Information

This product is for use by skilled persons or instructed persons. The installation of this product must comply with current IEE regulations. Terminals, including those factory fitted, must be checked for correct tightness before commissioning. All terminals should be periodically checked for correct tightness. The data herein serves only to describe the product and should not be regarded as representing guaranteed properties in the legal sense. We reserve the rights of modification, whilst every care has been taken in ensuring the accuracy of this catalogue, the Supplier accepts no liability whatsoever for any eventuality arising from errors or omissions within its catalogues, brochures or within any online presence.