

P-FS13DP

13A Switched Fused Connection Unit



**30
YEAR
GUARANTEE**

A modern range of ultra-slim, smooth-edged, moulded wiring accessories-manufactured in a bright white Urea.

Technical Drawing

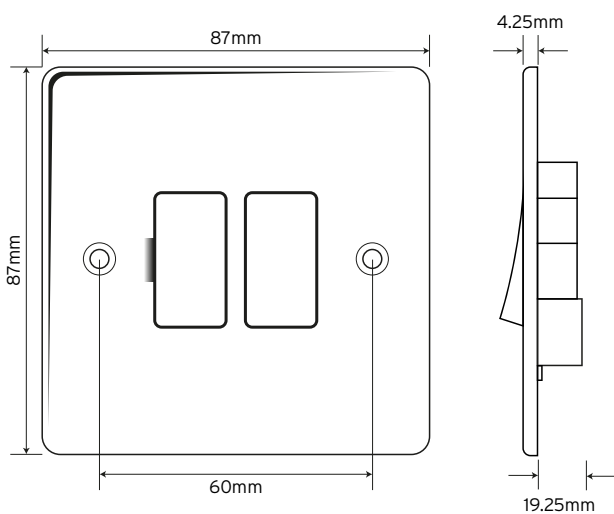

Technical Specifications

Material Composition:

Front Plate	Urea
Rear Housing	Urea
Terminals	Brass
Earth Strap	Mild Steel
Terminal Screws	Steel & Yellow Passivated Silver "on-lay" Copper/Brass Contacts
Voltage	240V ~ 50Hz
Current Rating	13A
Terminal Size	5mm Ø
Torque Value	2.0Nm
Cable Size	3x2.5mm ² or 2x4.0mm ²
Back Box Depth	35mm - 47mm
Twin Earth	Yes
Double Pole	Yes
Warranty	30 years
IP Rating	IP20
Operational Temperature	-5° to +40°C
Standards	BS 1363-4:1995+A4:2012 Fuses to BS 1362:1973