

PANEL COMPONENTS

PANEL MOUNTED STRAIGHT SOCKET 57484

General Characteristics

Standard	BS EN 60309-1 & 2
Voltage	230V
Amperage	32A
Poles	2P+E
Terminal capacity flex cable	2.5 to 6.0mm ²
Terminal capacity solid cable	2.5 to 10.0mm ²
Torque	1.1 Nm
Degree of Ingress	IP44
Weight	162g
Flange Dimension	70 x 70mm
Fixing Centres	56 x 56mm

Technical Drawing

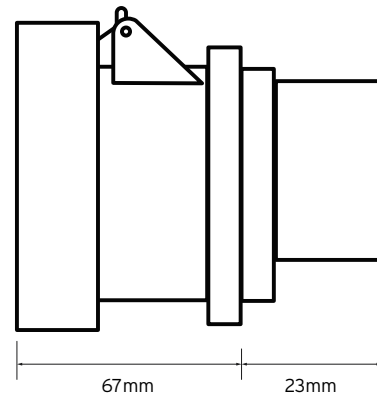
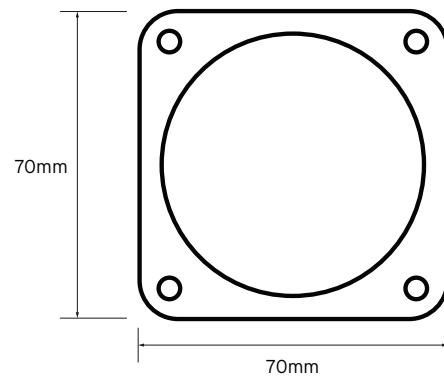

Additional Information

This product is for use by skilled persons or instructed persons. The installation of this product must comply with current IEE regulations. Terminals, including those factory fitted, must be checked for correct tightness before commissioning. All terminals should be periodically checked for correct tightness. The data herein serves only to describe the product and should not be regarded as representing guaranteed properties in the legal sense. We reserve the rights of modification, whilst every care has been taken in ensuring the accuracy of this catalogue, the Supplier accepts no liability whatsoever for any eventuality arising from errors or omissions within its catalogues, brochures or within any online presence.