

# niglon

Cable Management



## MSG2525

### Male Swivel Straight Connector

#### Technical Drawing

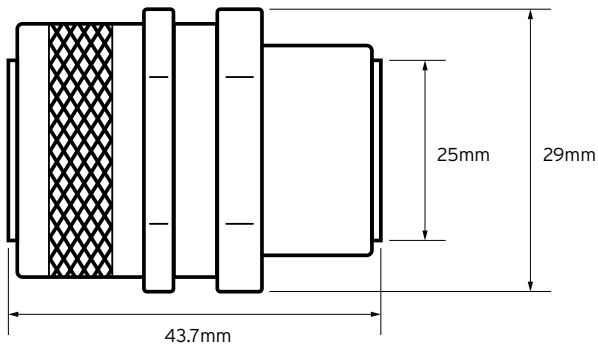

#### Technical Specifications

<b>Thread Diameter</b>	25mm
<b>Temperature</b>	-50°C to +300°C
<b>Standard of Compliance</b>	EN 61386
<b>Material</b>	Brass
<b>Finish</b>	Nickel Plated Brass
<b>IP Rating</b>	IP54
<b>Weight</b>	0.52600kg
<b>Dimensions</b>	43.7 x 29mm Ø

#### Features

- High tensile strength
- Oil resistant
- Corrosion resistant
- Inherently low fire hazard
- Can be used with threaded entries or knockouts
- Secured with a locknut