

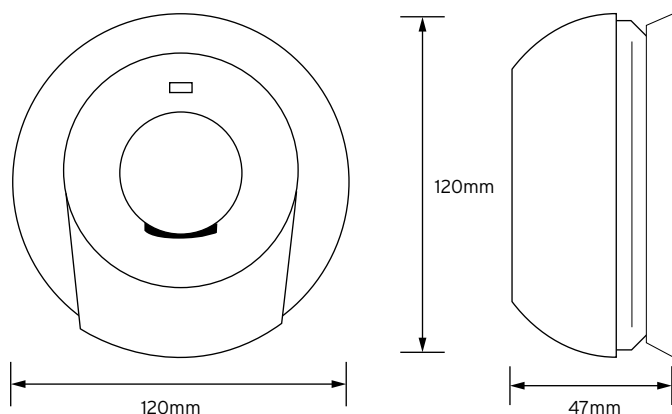

NFA01A

Interconnectable Photoelectric Smoke Alarm

Technical Drawing



Technical Specifications

Power Source	220-240Vac ~ 50-60Hz with 9v Battery backup (battery included)
Battery Backup	9V DC Carbon Zinc (Golden Power 1604D, Peak 1604P) , 9V Alkaline Battery (Gold Peak 1604A, Energizer 522, Duracell MN1604) or Lithium Battery (EVE CR9V/P)
Battery Backup Life	min 1 year
Operation Current	<40mA operation (In Alarm)
Ambient Humidity	10% - 90%
Alarm Sound Level	85 Decibels at 3 meters
Interconnect facility	max. 40 units (150 meters max.)
Sensitivity to smoke	0.65 - 1.52% per foot obstruction
Operation Temperature	0°C - 40°C
Sensor	Photoelectric
Approved	CE,BS EN14604:2005,
Dimensions	47 x 120 x 120mm (H x W x D)