

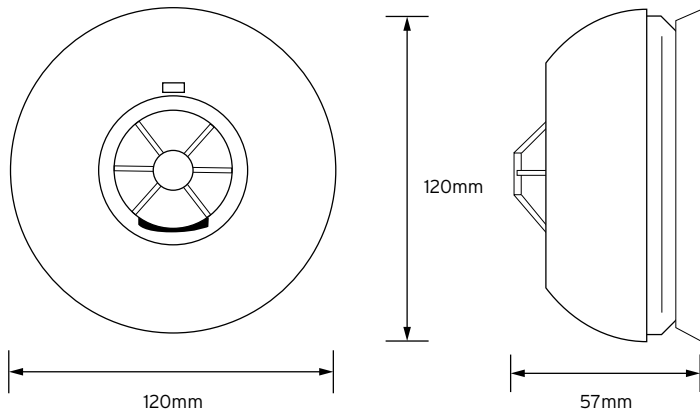

NFA03 Interconnectable Heat Alarm

Technical Drawing



Technical Specifications

Power Source	220-240Vac ~ 50-60Hz with 9v Battery backup (battery included)
Battery Backup	9V DC Carbon Zinc battery - Gold Peak GP1604D, Duracell MN1604
Battery Backup Life	min 1 year
Operation Current	<40mA operation (In Alarm)
Temperature Rating	60 °C fixed temperature only
Maximum Ambient	40 °C
Recommended Coverage	200m ²
Recommended Spacing	13.5m
Alarm Sound Level	85 Decibels at 3 metres (10ft)
Interconnect facility	max. 40 units (max. 150 meters)
Dimensions	120 x 120 x 57mm (H x W x D)