

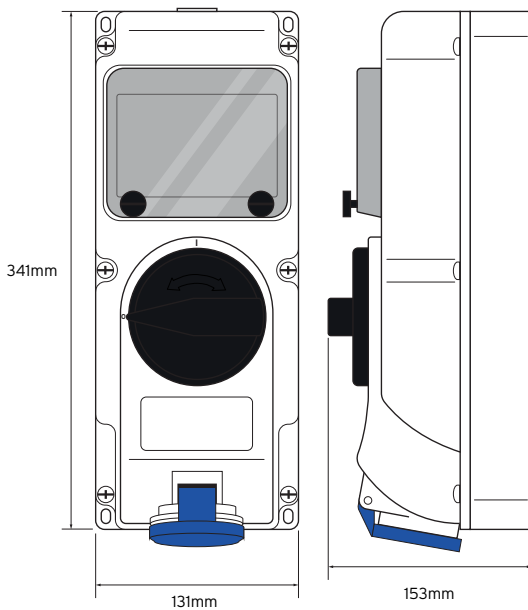

17766

IP44 Wall Mounted Interlocking Switched Socket

Technical Drawing



Technical Specifications

Material Composition	PC/ABS
Amps	32A
Volts	240V
Pin Configuration	2 p + e
IP Rating	IP44
Knockouts	Side - M25 x 3 Rear - M20/M25/M32 x 2
Max No. Modules	5
Module Blanks	6
Certified	OVE & CE
Standards	BS EN 60309-1&2
Dimensions	341mm H x 131mm W x 153mm D

