

niGLON

Wiring Accessories

H-WS131FS

IP66 1 gang 13A switched fused spur

Hurricane 6



10
YEAR
GUARANTEE

Constructed from a high impact resistant material. Hurricane products are designed to withstand ingress from dust and water, in both indoor and outdoor applications.

Technical Drawing

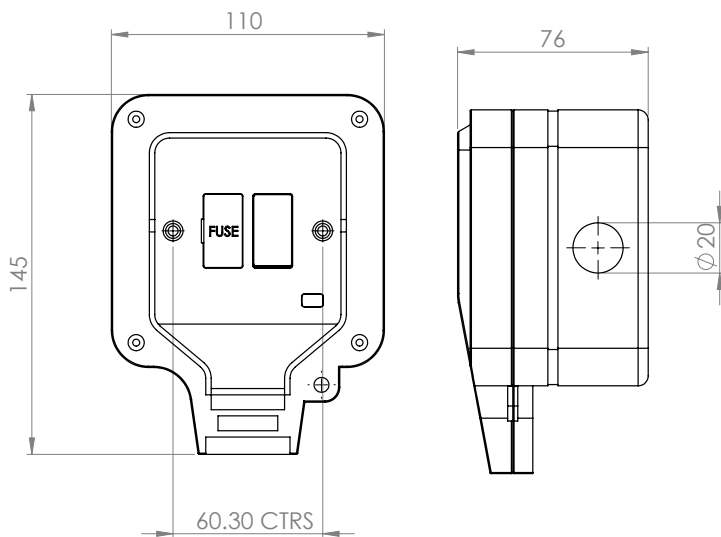

Technical Specifications

| Material Composition | |
|-------------------------|-------------------------------|
| Housing | Polycarbonate UV resistant |
| Socket Plate & Rear | Urea Front plate : Nylon Base |
| Knockouts | 5 x 20mm |
| Voltage | 240V ~ 50Hz |
| Current Rating | 13A |
| Torque Value | 1.2Nm |
| Pad lockable | Yes |
| Double Pole | Yes |
| Twin Earth | Yes |
| Neon Indicator | Yes |
| Cable Size | 3x2.5mm ² |
| IP Rating | IP66 |
| Warranty | 10 years |
| Operational Temperature | -5° to +40°C |
| Standards | BS1363 Fuses to BS 1362:1973 |
| Mounting | Surface |
| Dimensions | 145 x 110 x 76mm (HxWxD) |