

niglon

Wiring Accessories

BLSHOPW Pre-Wired Batten Lampholder



Technical Drawing

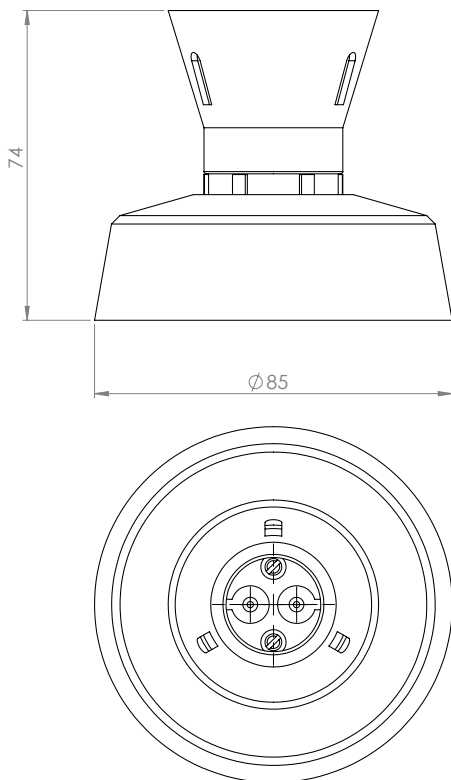

Technical Specifications

Material:	Polycarbonate
Standard of Compliance:	BS EN 61184
No. of Terminals:	4
Rating	T2
Bulb Fixing:	Bayonet
Dimensions:	Ø 85mm x 74mm

Features

- Clear base for ease of installation
- H.O. skirt included