

# niglon Control & Automation

## ENCLOSURES

### STAINLESS STEEL ENCLOSURE SS504020



Wall mounting stainless steel enclosure with brushed finish. The polyurethane gasket keeps its profile over time to give a high degree of protection against water and dust. Door opens 125° and is reversible. Welded earth studs top and bottom. Fitted, galvanised backplate has return edges for extra rigidity

#### General Characteristics

Standards	IEC 61439-1, IEC 60529, IEC 62208, IEC 62262
Ingress Protection	IP65
Height	500mm
Width	400mm
Depth	200mm
Material	304 Grade
Enclosure Steel Thickness	1.2mm
Backplate height	454mm
Backplate width	354mm
Useable depth with backplate fitted	176mm
Backplate Thickness	2mm
Number of Locks	1
Operating Temperature	-5°C to +40°C
Operating Relative Humidity at +20°C	90%
Operating Relative Humidity at +40°C	50%
Weight	15.9 Kg

#### Available Accessories

Plinth	SPS4020
Stainless Steel Bit Lock	SSBL
Spare T Bit Key	STBK
Wall Mount Brackets (pack of 4)	SSWB
220mm Earth strap	ES22

#### Technical Drawing

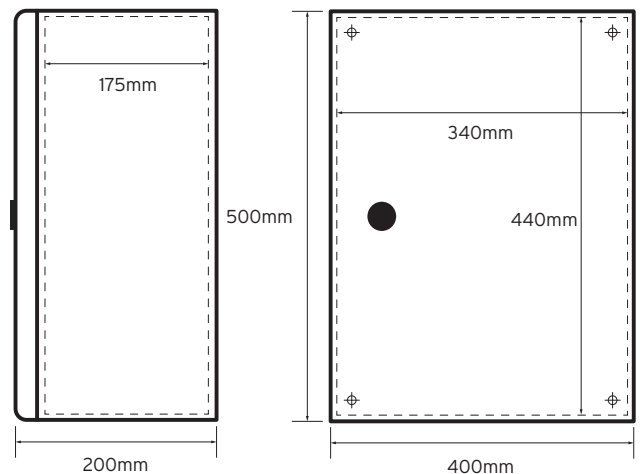

#### Additional Information

The data herein serves only to describe the product and should not be regarded as representing guaranteed properties in the legal sense. We reserve the rights of modification, whilst every care has been taken in ensuring the accuracy of this catalogue, the Supplier accepts no liability whatsoever for any eventuality arising from errors or omissions within its catalogues, brochures or within any online presence.